

Model MC208X Digital Pressure Switch (Pressure Controller)



MC208X Pressure Switch (Pressure Controller) is a kind of product for pressure measurement and control. The product can be used to measure the pressure of various gases, liquids and other media. It can set pressure control points to achieve continuous pressure measurement and switching control. When the pressure reaches the preset value, the output control signal is turned on or off, so that the automatic control can be realized. The product has the advantages of high precision, low hysteresis, quick response, stable and reliable performance, easy operation and convenient installation. The same is a high technology product of the microcomputer technology used for the automatic control of pressure. The product is also an alternative for traditional pressure gauge.

The product is characterized by:

- Long life.
- Simple wiring.
- The product can work for a long time in the environment of vibration.

Technical Parameters

Display: -1999~9999, multi unit switching

Accuracy: 0.2%

Control output: relay, 4-20mA, RS485

Pressure control points and hysteresis: Can be set in full range

Contact capacity: 220V/3A, 24V/10A

Power consumption: 1W

Input voltage: 24V/220V optional

Working temperature: -20 -70°C

Compensation temperature: -10 -60°C

Stability: $\pm 0.2\%$ FS/year

Overload capacity: 200-300%

Housing Material: ABS engineering plastic or cast aluminum alloy

Ordering Codes (Model Selections)

MC208	Pressure Switch (Pressure Controller)	
-	Housing type	0: 81mm display diameter (1 relay output) 1: 72mm display diameter (2 relays output) 2: Ex-proof cast alloy aluminum (2 relays output) 25: Ex-proof cast alloy aluminum (5 relays output) 7: Back thread connection
-	Pressure range	e.g. 0-10bar or 0-1MPa etc.
-	Wet Part Material	-S4: 304 Stainless Steel -S6: 316 Stainless Steel -S0: specified
-O	Signal Output	1: 4-20 mA 2: RS485 3: specified
-V	Power Supply	1: 24VDC 2: 220VAC
-T	Temperature	1: Normal 2: High Temperature
-A	Installment type	1: thread 2: flange 3: clamp 4: customer specified
-	Size of installment	e.g. for A1, -1/2BSP or -M20*1.5 etc.; for A3, -2" or 3" etc.

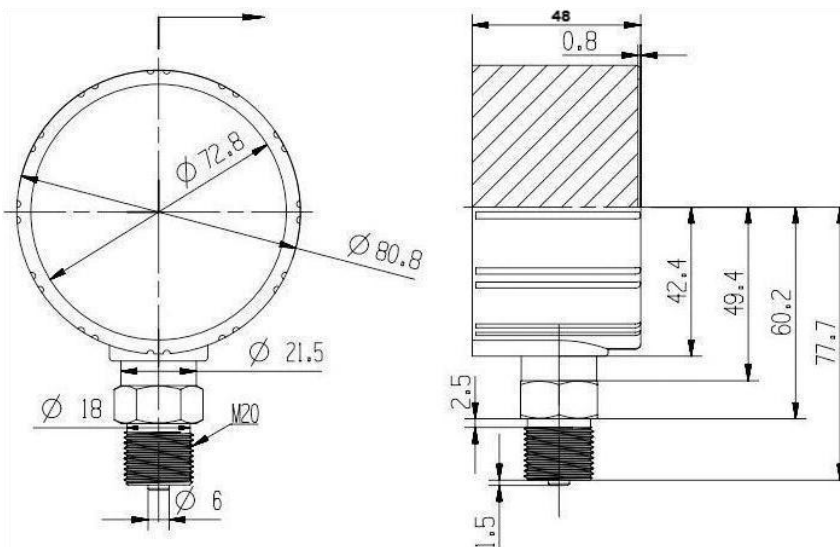
Dimensions
MC2080 type:

MC2081 type:

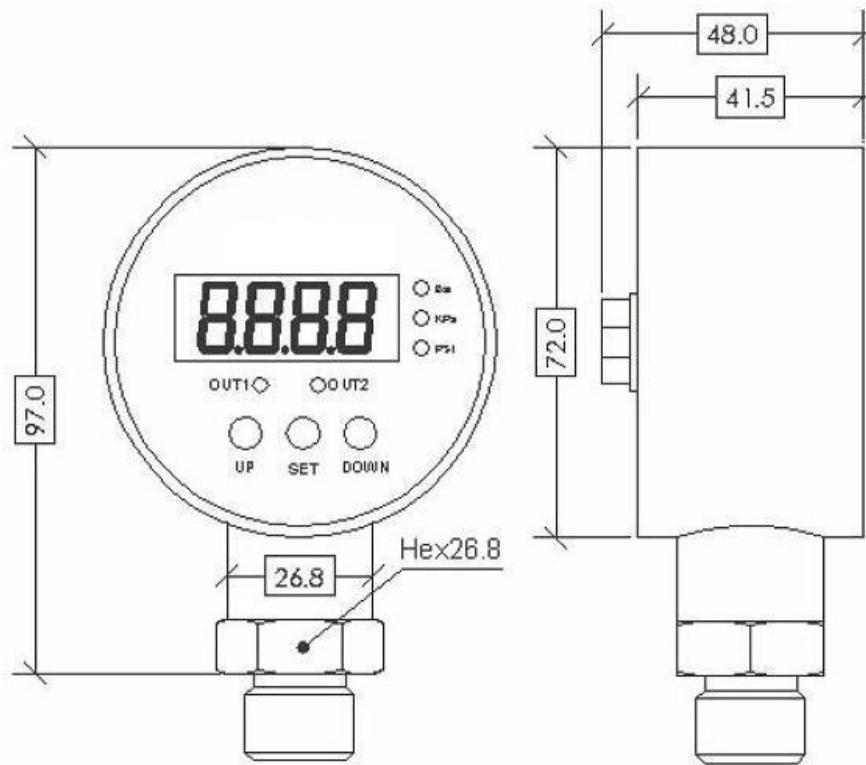

MC2082 and MC20825 type:

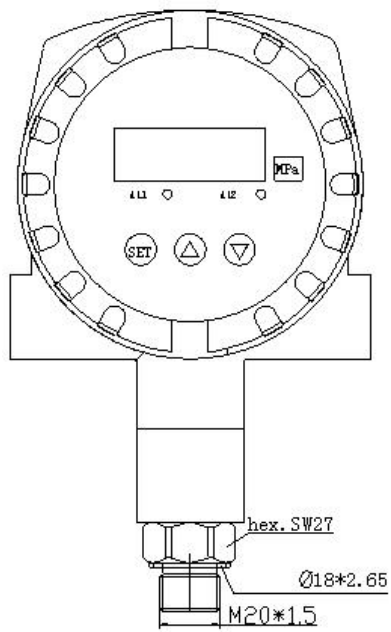

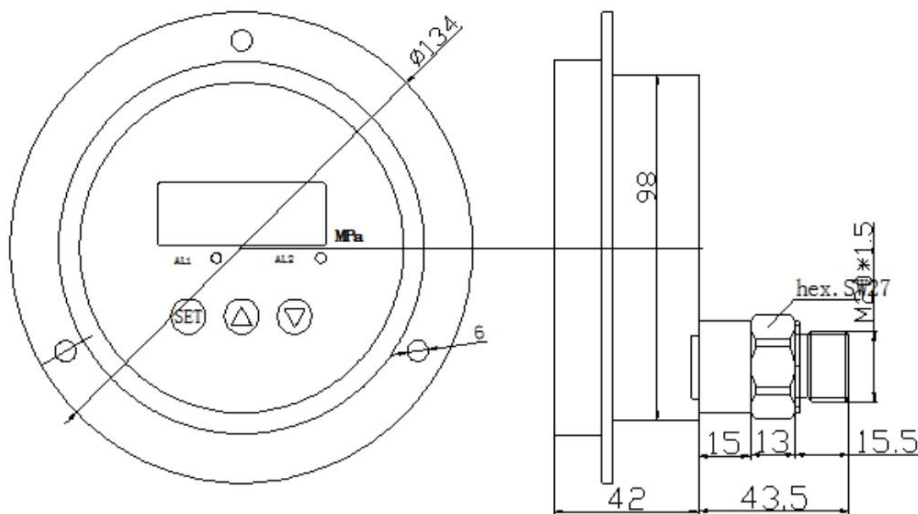
MC2087 type:

Controlling Points Preset Step (Take MC2080 as example):

- 1, Turn on the power supply, "run" light will flash;
- 2, Press the "on / off" button, turn off the "running" light.
- 3, At zero pressure, the display should be shown as 0. If not for the 0, this is because of the installation of different conditions or different atmospheric pressure caused by the slight deviation which can be ignored. You can also press the down arrow key to clear.
- 4, Press the "Settings" button, the "upper limit" lights, press the "down arrow key" or "up arrow key" to set the upper limit switch value.
- 5, Press the "Settings" button, "lower limit" lights, press the "down arrow key" or "up arrow head" key to set the lower limit value.
- 6, Press the "Settings" button to save the settings data.
- 7, Press the "on / off" button, "run" lights flashing, the device starts to work.
- 8, If you need to change the output of the instrument from normally open to normally closed, or from the normally closed to normally open, please refer to the following steps:

press "set" button for 3 seconds, change the display into "1111", click "Settings" button, then show A2C, click "Settings" button, change "0" or "1" into "1" or "0" (the factory default settings for "0"), click "Settings" button, then show A2C, press "upper arrow key", display will show END , confirm exit.

Controlling Points Preset Step (Take MC2082 as example):

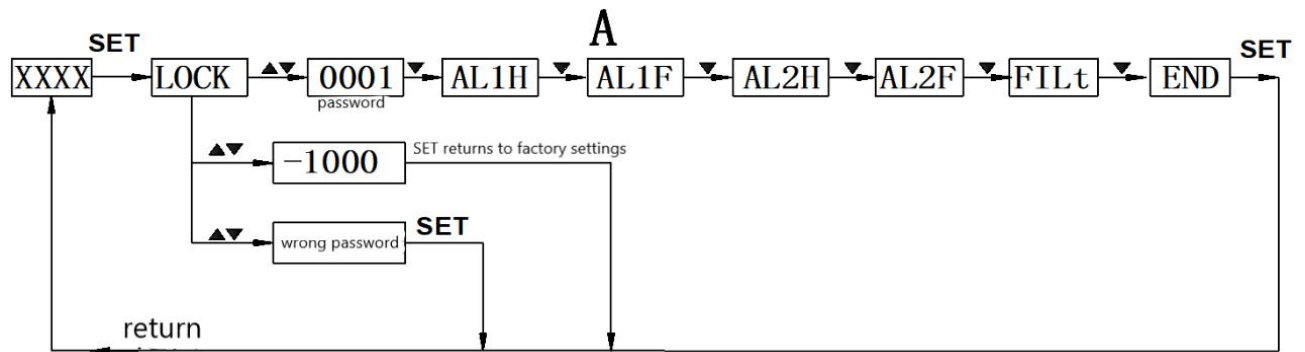
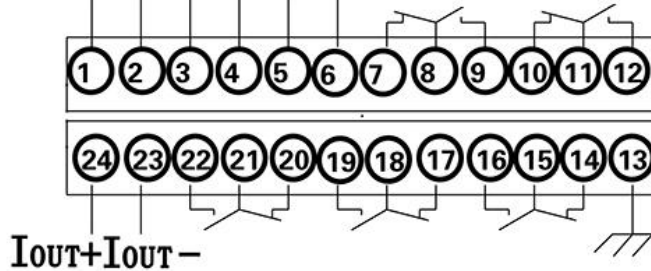
485B 485ADC+ GND AC220



AL1H is the pull-in value of switch 1,AL1F is the release value of switch 1
 AL2H is the pull-in value of switch 2, AL2F is the release value of switch 2
 FILt this value is the display filter coefficient to prevent the display from jumping due to pressure fluctuation. The larger the filtering coefficient is, the more stable the display is, but the more lagged it is. 3 ~ 10 options
 END save exit

Note: the switch point is determined by the configuration of the pull in value and the release value. When the pull in value is greater than the release value, it is the upper limit alarm output (normally open function). When the pull in value is less than the release value, it is the lower limit alarm output (normally closed function). The difference between the pull in value and the release value is the return difference of the switch point.
 For example: to set the switch point 1 as the upper limit alarm output (normally open function) to draw at 4MPa and to disconnect at less than 3.95mpa; the switch point 2 as the lower limit alarm output (normally closed function) to disconnect at 10MPa and to draw at less than 9.95mpa:

Enter the menu: settings

AL1H=4.00 AL1F=3.95 AL2H=9.95 AL2F=10.00

Press "set" key ● display "lock" (prompt for password)

Press the ▲ or ▼ key to input the password "1", ● press the "set" key to confirm.

Press the▲ or▼ key to scroll up or down for menu selection (al1h, al1f, al2h, al2f, end)

Press "set" key to enter the selected menu. Press the▲ or▼ key to change the setting.

Press the "set" key to confirm. If necessary, select other menus to modify.

After modification, select "end" and press "set" to confirm save and exit.

If no key is pressed for 30 seconds, it will exit the setting state automatically, but the modified data will not be saved.