

# MCT80XH On-site Display Isolated Temperature Transmitter

## Product Introduction

The MCT80XH on-site display isolated temperature transmitter is used for the input of resistance temperature detector (RTD) signal and thermocouple (TC) signal and for two-wire or three-wire analog signal output (4–20mA). It is configured by the RS485 (MODBUS RTU protocol) or the HART protocol.

## 1 Instrument Model

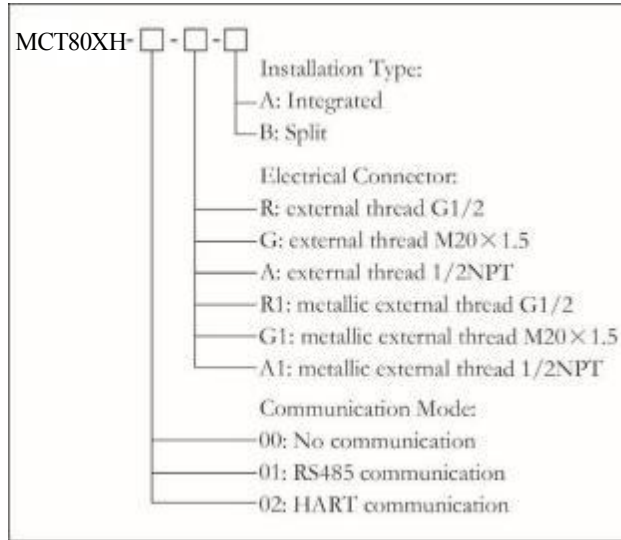

## 2 Structure Diagram

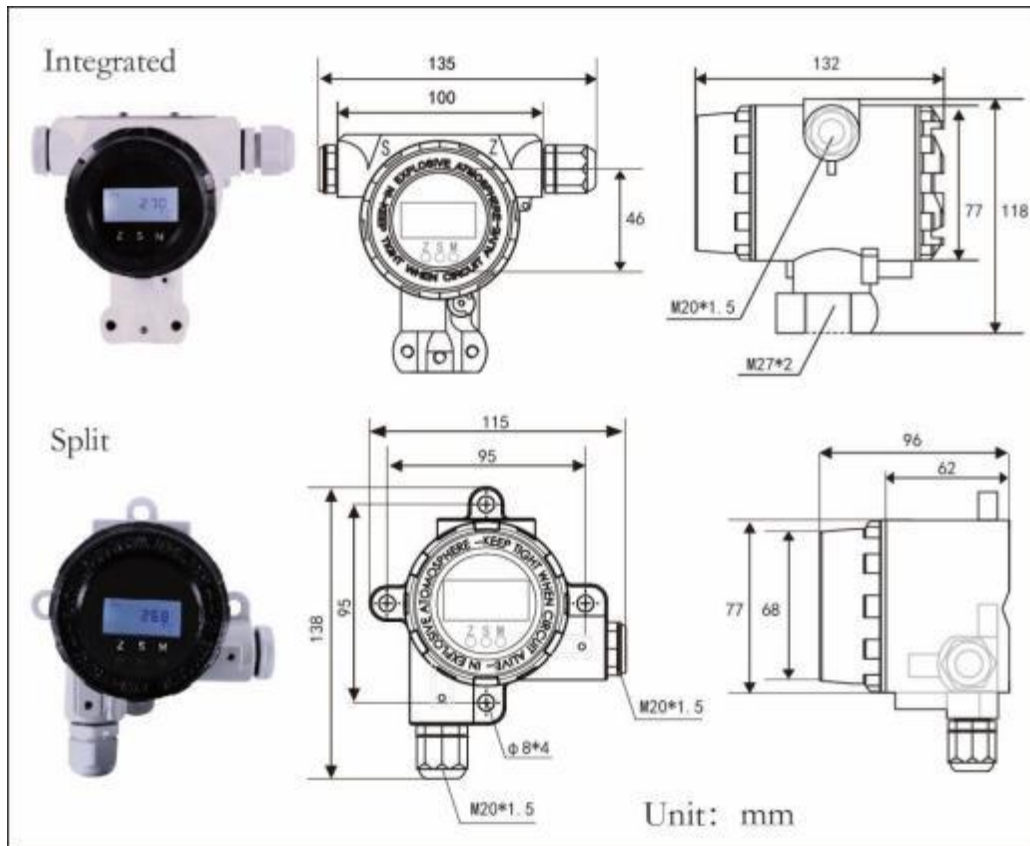

### 3 Wiring Diagram

Transmitter head part wiring description:

Disconnect the head part from the socket terminal and connect the cables according to the figure on the right.

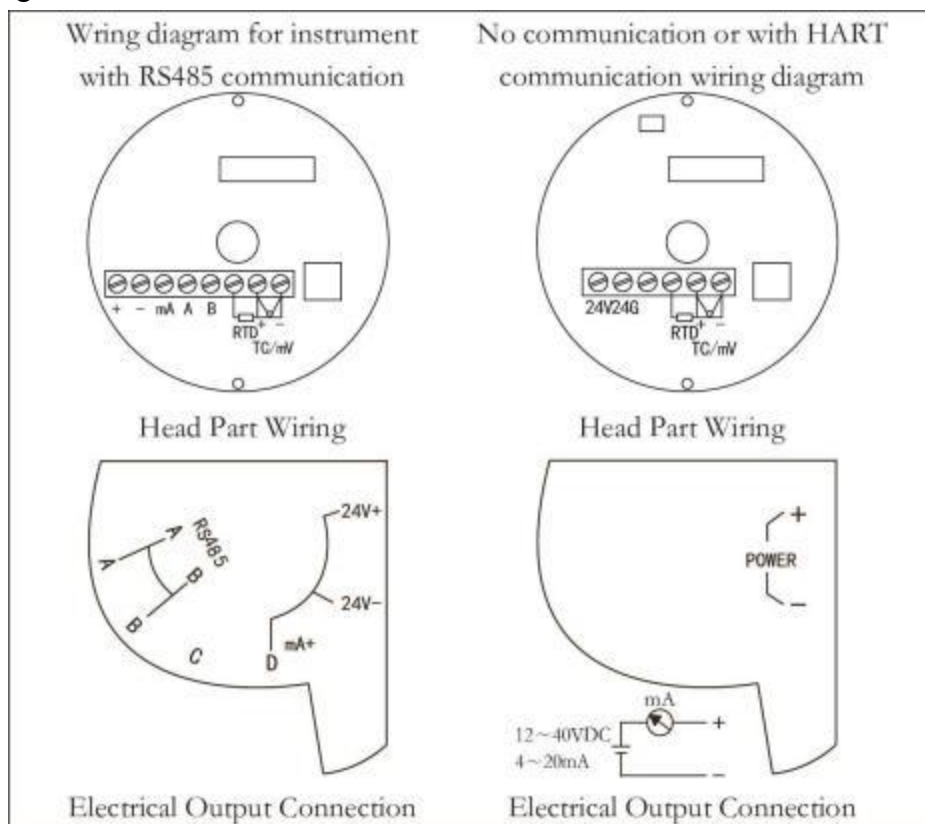

NOTE: No electrical output wiring diagram is available for the split temperature transmitter.

### 4 Technical Parameters

Input	
Input Signal	Resistance temperature detector (RTD) and thermocouple (TC)
Temperature Range of Cold Junction Compensation	-20 ~ 70 C
Compensation Precision	± 1 C
Output	
Output Signal	4 – 20mA or 4 – 20mA adds the HART protocol
Load Resistance	$RL \leq (U_e - 12) / 0.022$
Output Current for Upper/Lower Limit Overflow Alarm	I <sub>H</sub> =21mA、I <sub>L</sub> =3.8mA
Output Current for Input Break Alarm	Settable
Power Supply	
Power Supply Voltage	DC12 ~ 40 V
Other Parameters	
Transmission Precision (20°C)	0.1%FS
Thermal Drift	0.0075%FS/C
Response Time	700ms reaching 90% of the final value
Environment Temperature	-20 ~ 70 C

Insulating Strength (between input and output)	1500 Vrms (1 min, no spark)
Insulation Resistance (between input and output)	$\geq 100M\Omega$ (500VDC)
Protection Class	IP65, anti-dust and anti-spray
Connection	M27×2 internal thread (integrated)
EMC	Comply with the industry equipment application requirements in GB/T18268 (IEC 61326- 1).

#### Input Type and Transmission Precision:

Model	Symbol	Signal Type	Measurement Range	Minimum Measurement Range	Conversion Accuracy (larger value)
Resistance temperature detector (RTD)	Pt100	Pt100	-199.9~850.0C	20C	$\pm 0.1\%$ range Or $\pm 0.2C$
	Cu50	Cu50	-50.0~150.0C	20C	$\pm 0.1\%$ range Or $\pm 0.2C$
Thermocouple (TC)	B	B	400~1800C	500C	$\pm 0.1\%$ range Or $\pm 1.5C$
	E	E	-100~1000C	50C	$\pm 0.1\%$ range Or $\pm 0.5C$
	J	J	-100~1200C	50C	$\pm 0.1\%$ range Or $\pm 0.5C$
	K	K	-180~1372C	50C	$\pm 0.1\%$ range Or $\pm 0.5C$
	N	N	-180~1300C	50C	$\pm 0.1\%$ range Or $\pm 0.5C$
	R	R	-50~1768C	500C	$\pm 0.1\%$ range Or $\pm 1.5C$
	S	S	-50~1768C	500C	$\pm 0.1\%$ range Or $\pm 1.5C$
	T	T	-200~400C	50C	$\pm 0.1\%$ range Or $\pm 0.5C$

#### NOTE:

1. Environment temperature for measuring the above precision is  $20C \pm 2C$ .
2. The output precision “%” is the allowance of the set range.
3. When measuring the TC, the allowance of cold junction compensation should be considered. The internal allowance of cold junction compensation is smaller than or equal to  $\pm 1^{\circ}C$ .

## 5. Operations

### 5.1 Button Descriptions

From the left to right, the buttons are the increase button, decrease button and set button respectively.

Increase button	Used for increasing or modifying the current flickering position. Press and hold
-----------------	--

(Z)	the button to move the modification position to left.
Decrease button (S)	Used for decreasing or modifying the current flickering position. Press and hold the button to move the modification position to right.
Set button (M)	Used for switching among menu parameters. After modifying and saving the menu, press and hold the button to back to the measurement value screen.

### 5.2 Primary Menu Settings

In the working status, press the Set button to display parameters on the screen and then press the Increase or Decrease button to set the parameter.

Symbol	Parameter	Range	Description	Factory Default Value
LOCK	Lock	0~10000	Electronic lock Lock=132: Enter the secondary menu.	132
DIS1	dIS1	0~2	Digital display for the middle row dIS1=0: measurement value dIS1=1: output current value dIS1=2: output percentage	0
DIS2	dIS2	0~2	dIS2=0: Only display the digital in the middle row. dIS2=1: Display the digital of the middle and bottom row. dIS2=2: display all	2

### 5.3 Secondary Menu Settings

In the working status, press the Set button to display parameters on the screen. When the Lock=132, press and hold the Set button for 3 seconds to enter the secondary menu, and then press the Increase or Decrease button to set the parameter.

Symbol	Parameter	Range	Description	Factory Default Value
Pn	Pn	Refer to the Input Type Table.	Sensor type	Pt100
Unit	Unit	°C, F, R, K, Ohm (reserved) and mV (reserved)	Temperature unit: °C: Celsius temperature F: Fahrenheit temperature R: Rankine temperature K: thermodynamic temperature	C
dP	dP	0~2	Decimal Place dP=0: No decimal place. dP=1: The decimal point is in the tens. dP=2: The decimal point is in the hundreds.	1
FK	FK	0.0~5.0	Damping coefficient	0
PL	PL	0~1000	Lower range limit	0
PH	PH	0~1000	Upper range limit	1000
oFEt	oFEt	-100~100	Measurement value offset	0
CJC	CJC	-50~50	Modification of cold junction temperature	0
ARm	ARm	3.8~21.0	Alarm output value	21.0

<i>dir</i>	Dir	0 ~ 1	Current output direction diR=0: output 4 – 20mA diR=1: output 20 – 4mA	0
<i>Addr</i>	Addr	1 ~ 247	Communication stack number (248 is the fixed stack number.)	1
<i>baud</i>	Baud	1200,2400,4800,9600,19200	Baud rate	9600
<i>bits</i>	Bits	8N1, 8N2, 8O1, 8O2, 8E1, 8E2	Communication status bits	8N1

## 6 Instrument Communication Settings

This instrument can communicate to the master. The master can achieve the parameter setting, data capture and remote monitoring for this slave.

Technical Indications:

Communication Mode: Serial communications: RS485 and RS232; Baud rate: 1200 – 19200bps

Data format: One start bit, eight data bits and one stop bit.

Refer to the following table for detailed parameters.

No.	Parameter Name	Communication Address	Type	Value Range	Remark
1	Software version	0	R		
2	Internally reserved				
3	Internally reserved				
4	Measurement value (16 digits, including symbols)	5	R		One decimal place
5	Current value (16 digits, including symbols); Wrote as the fixed current output.	6	R/W	3.800~21.000	Three decimal place
6	Output percentage (16 digits, including symbols)	7	R		One decimal place
7	Cold junction temperature (16 digits, including symbols)	8	R		One decimal place
8	Temperature sensor type	9	R/W	0 ~ 9	Table 1
9	Lower range limit of temperature	10	R/W		One decimal place
10	Upper range limit or temperature	11	R/W		One decimal place
11	Offset value	12	R/W	- 100.00~100.00	Two decimal place
12	Temperature unit	13	R/W	32 ~ 37	Table 2
13	Damping time	14	R/W	0.0 ~ 5.0	One decimal place
14	Current output direction	15	R/W	0 ~ 1	
15	Content displayed on the main digital	16	R/W	0 ~ 2	
16	Displayed content	17	R/W	0 ~ 2	
17	Decimal Place	18	R/W	0 ~ 2	
18	Current zero adjustment	19	R/W	3.800~21.000	Three decimal place
19	Current full adjustment	20	R/W	3.800~21.000	Three decimal place
20	Modification of cold junction	21	R/W	-50.0 ~ 50.0	One decimal place

